

Model S Shrimp Waste Separator

**Laitram
Machinery**

Specifications

Floor Space:

1.27 m x 2.03 m; 2.58 m²
(4 ft 2 in x 6 ft 8 in; 28 ft²)

Power: Available in most major voltages, including 208/220/240/480 V (60 cycle), and 380 V (50 cycle); 3 phase. 1 hp motor included.

Water: 38 liters (10 gallons) per minute.

Net Weight: 340 kg (750 lb).

Approx. Gross Crated Weight: 354 kg (780 lb).

Specifications are subject to change without notice.



The Laitram® Model S Waste Separator continues the cleaning process by separating from the edible meats the waste material already detached by the Model C Cleaner. Shrimp pass through the Model S in a continuous flow from the Model C Cleaner (or from the Model CSC Lift Conveyor) without operator contact.

SAFETY FEATURES

The Model S includes safety covers over the rollers and a safety stop switch to prevent operation when the upper frame is opened.

SIMPLE TO OPERATE & MAINTAIN

Like all Laitram equipment, the Model S is constructed of stainless steel and is easy to clean. The Separator's simple design allows adjustments to be made quickly and easily during operation.

LAITRAM QUALITY

Since 1949, Laitram has been a supplier of food processing equipment throughout the world. We have built our reputation on quality machinery, expert service and replacement parts. Call us. Together, we'll select the best system to meet your processing needs.



Swimmerets, gristle and debris pass through stainless steel rollers, efficiently separating waste material from edible meats.



Adjustment handle allows roller spacing to be adjusted quickly and easily for efficient operation.

Model S Shrimp Waste Separator

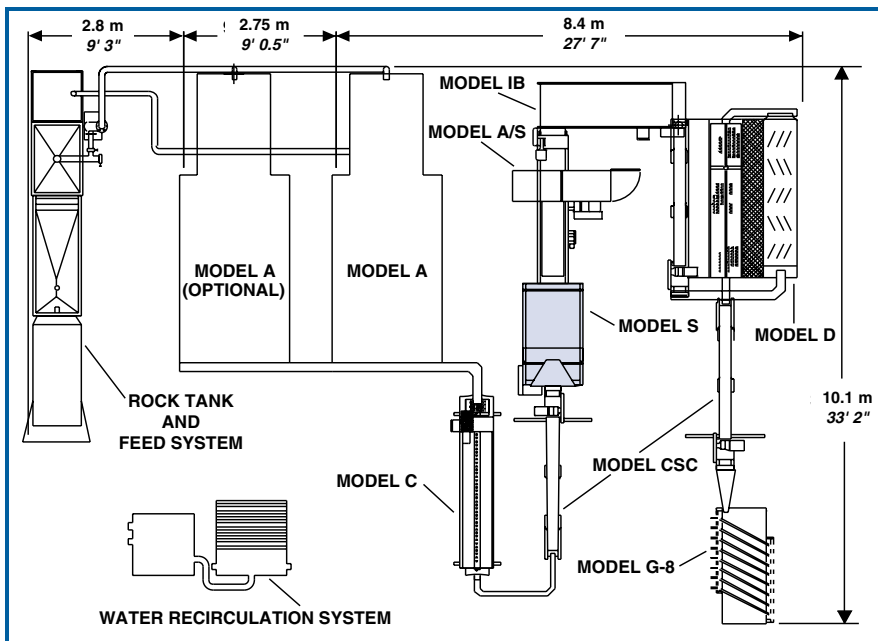
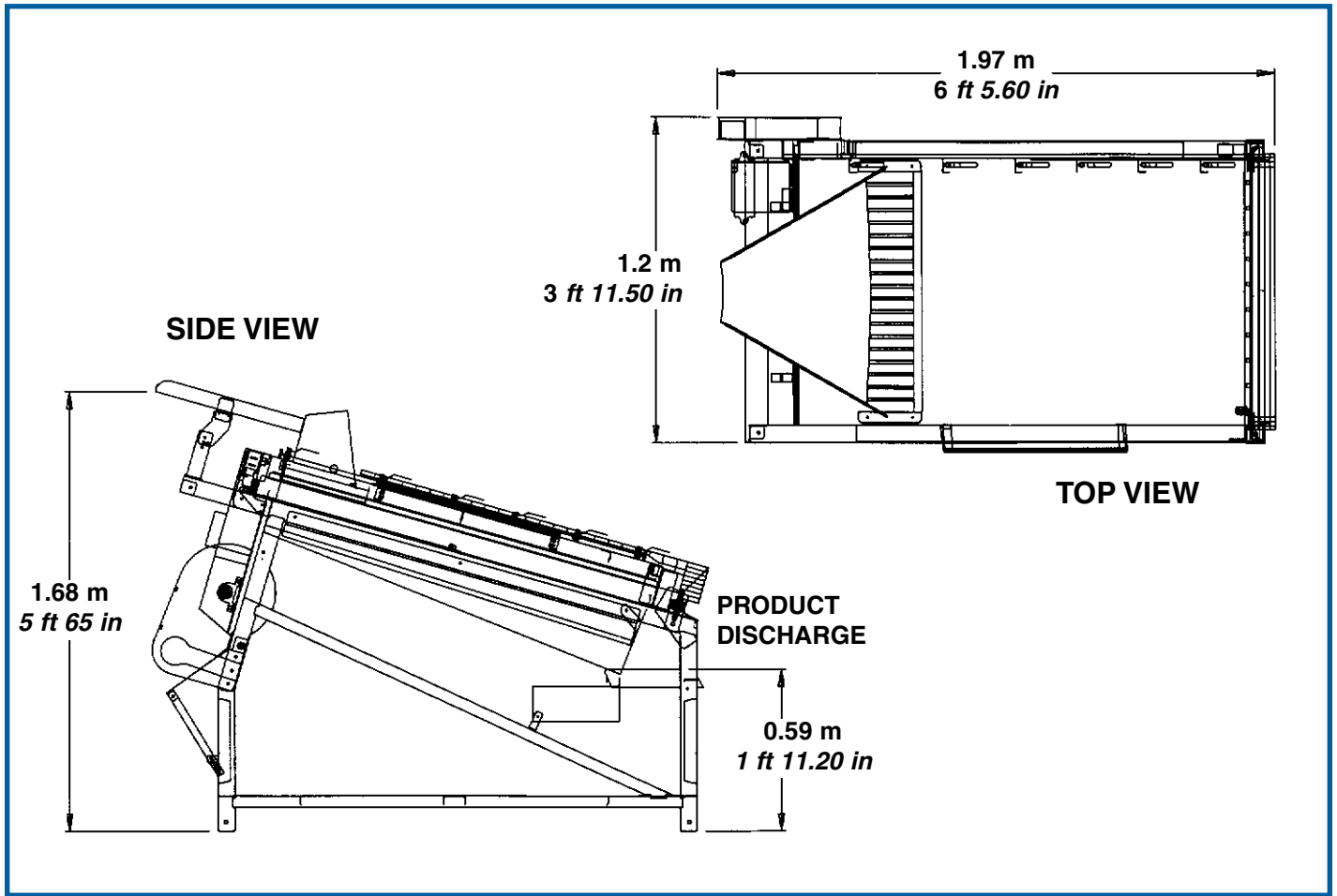

TYPICAL PLANT LAYOUT

Suggested arrangement of a complete Laitram Warm Water Shrimp Processing System. Each machine in the line can process the output of two Model A Automatic Shrimp Peelers (the second peeler is optional).

**Laitram
Machinery**

Laitram Machinery, Inc. • P.O. Box 50699 • New Orleans, Louisiana 70150 • USA
 Tel: 504 733 6000 • Toll Free: 800 533 8253 • Fax: 504 733 2143
 Email: lm.sales@laitram.com • Internet: <http://www.laitrammachinery.com>