

# Model G-8 Grader

**Laitram  
Machinery**



## Specifications

### Floor Space:

3 ft 5 in x 7 ft; 25 ft<sup>2</sup>  
(1.04 m x 2.13 m; 2.2 m<sup>2</sup>)

**Power:** Available in most major voltages, including 208/220/240/480 V (60 cycle), and 380 V (50 cycle); 3 phase. 1 hp motor included.

**Water:** 5 gallons per minute (19 LPM).

**Net Weight:** 335 lb (152 kg)

**Approx. Gross Crated Weight:**  
595 lb (270 kg)

*Specifications are subject to change without notice.*

The Laitram Model G-8 Grader accurately sizes up to 1200 lb (545 kg) of raw, peeled shrimp per hour (depending on shrimp size). Shrimp are graded as they pass under a series of aluminum wire wrapped rollers. Each roller can be raised or lowered to allow precise sizing of up to 9 different grades. Roller adjustments can be made at any time during the grading process.

The Model G-8 may remain in the processing line even when grading is not required. Spiral rollers can be raised to allow non-graded shrimp to pass through.

## EASY TO OPERATE AND CLEAN

Like all Laitram equipment, the Model G-8 is constructed of type 304 stainless steel and is easy to clean. It requires limited power and water. Once initial adjustments are made, the Model G-8 requires little supervision. All components are precision machined and assembled.

## LAITRAM QUALITY

Since 1949, Laitram has been a supplier of food processing equipment throughout the world. We have built our reputation on quality machinery and exceptional service. Call us. Together, we'll select the best system to meet your processing needs.

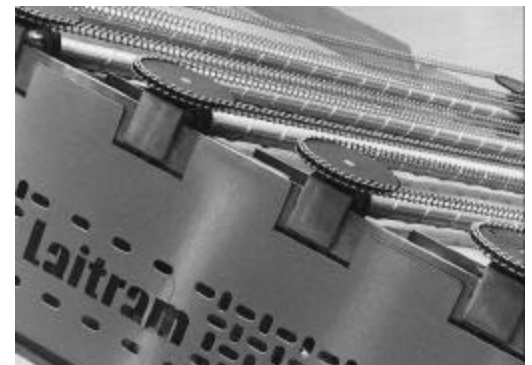

*The G-8 Grader is constructed of stainless steel for years of trouble-free performance.*



*Revolving spiral rollers are raised or lowered to allow grading of different sizes.*

# Model G-8 Grader

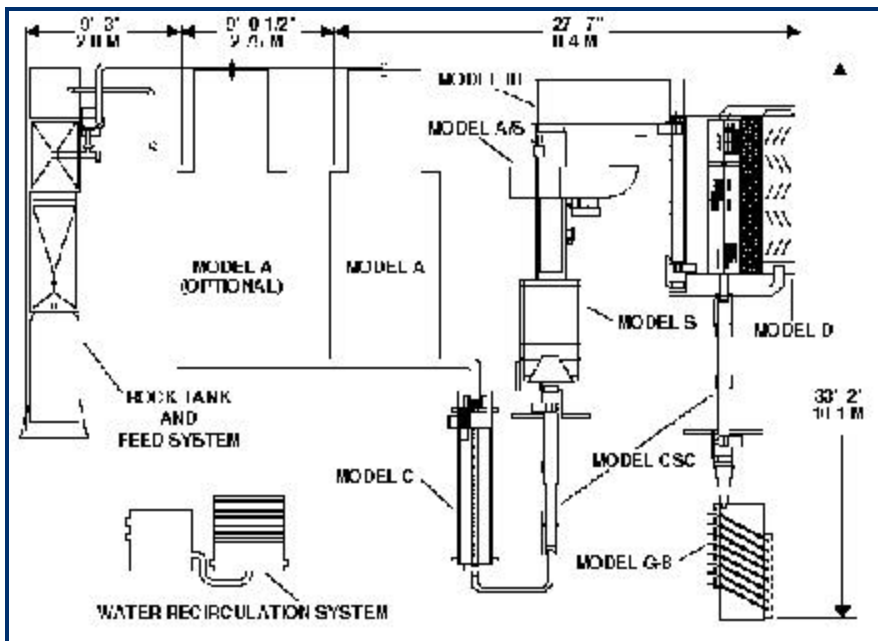
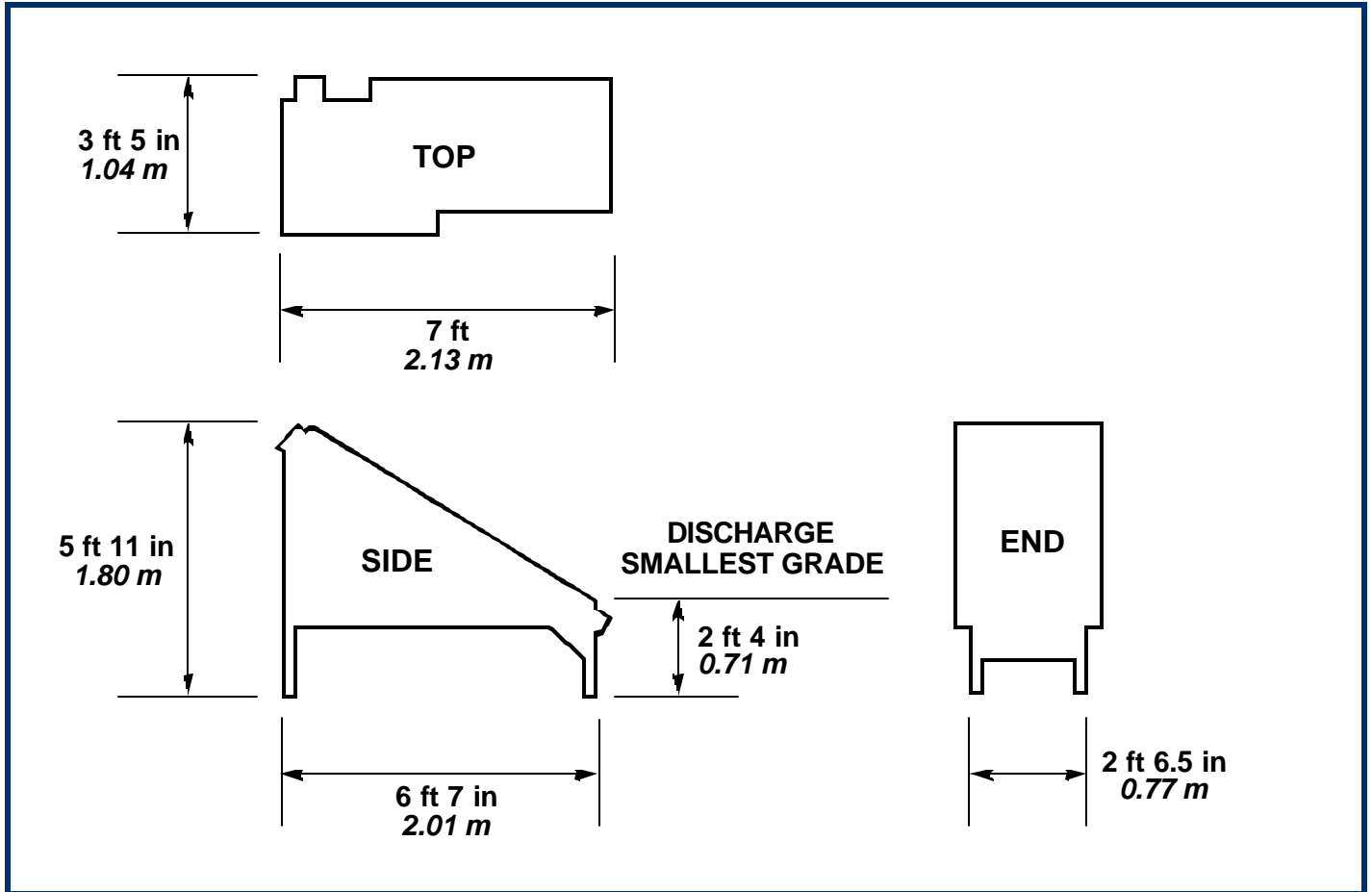

## TYPICAL PLANT LAYOUT

Suggested arrangement of a complete Laitram Model A shrimp processing line. Total floor space required with one peeler is approximately 900 ft<sup>2</sup> (84 m<sup>2</sup>). Each machine in the line can process the output of two Model A Automatic Shrimp Peelers (the second peeler is optional).

**Laitram  
Machinery**

Laitram Machinery, Inc. • P.O. Box 50699 • New Orleans, Louisiana 70150 • USA  
 Tel: 504 733 6000 • Toll Free: 800 533 8253 • Fax: 504 733 6111  
 Email: lm.sales@laitram.com • Internet: <http://www.laitrammachinery.com>