

# Model A Automatic Shrimp Peeler

# Laitram Machinery

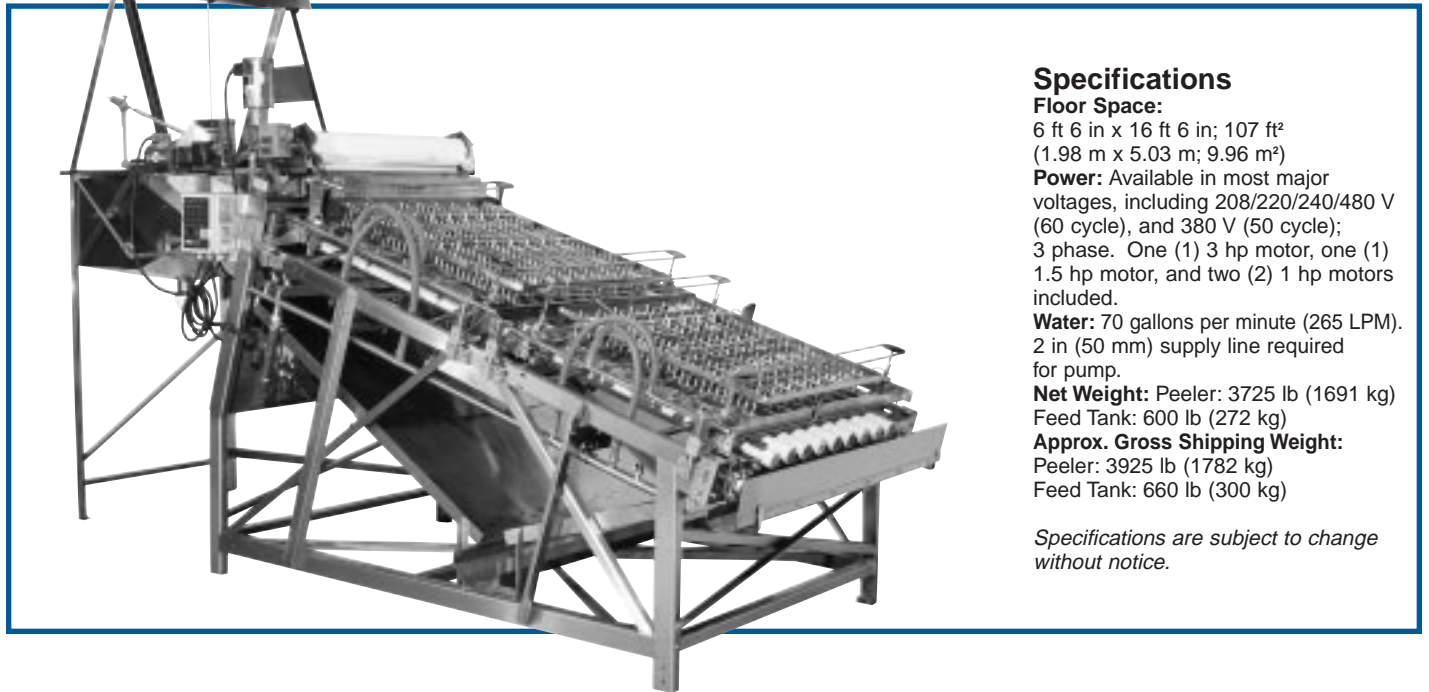

## Specifications

### Floor Space:

6 ft 6 in x 16 ft 6 in; 107 ft<sup>2</sup>  
(1.98 m x 5.03 m; 9.96 m<sup>2</sup>)

**Power:** Available in most major voltages, including 208/220/240/480 V (60 cycle), and 380 V (50 cycle); 3 phase. One (1) 3 hp motor, one (1) 1.5 hp motor, and two (2) 1 hp motors included.

**Water:** 70 gallons per minute (265 LPM). 2 in (50 mm) supply line required for pump.

**Net Weight:** Peeler: 3725 lb (1691 kg)  
Feed Tank: 600 lb (272 kg)

**Approx. Gross Shipping Weight:**  
Peeler: 3925 lb (1782 kg)  
Feed Tank: 660 lb (300 kg)

*Specifications are subject to change without notice.*

The Laitram® Model A Automatic Shrimp Peeler peels approximately 900 lb (410 kg) of head-on or headless shrimp per hour. It peels shrimp ranging in size from 10-200 count/lb or 22-440 count/kg. First, shrimp are bulk-loaded into a feed tank capable of holding approximately 300 lb (140 kg) of product. Shrimp are then conveyed to the Model A where the actual peeling process begins.

## PRODUCT YIELD

Yield depends on such factors as product species, quality, and maturity. Adjustments made to the equipment which impact product yield should be carried out by trained operators. Proper maintenance and cleaning are important.

## EASY TO OPERATE AND CLEAN

One operator can oversee the operation of up to two Model A Peelers. All controls are conveniently situated on one side of the machine for easy reach. Like all Laitram equipment, the Model A is constructed of stainless steel and is easy to clean. All components are precision machined and assembled.

## LAITRAM QUALITY

Since 1949, Laitram has been a supplier of food processing equipment throughout the world. We have built our reputation on quality machinery, expert service and replacement parts. Call us. Together, we'll select the best system to meet your processing needs.



*Shells are pulled through rollers away from edible meats.*

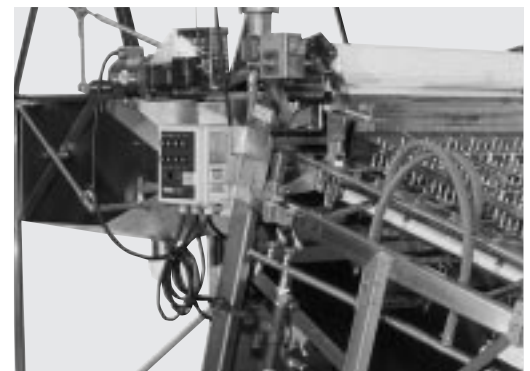

*Laitram machines are ruggedly constructed of stainless steel to provide years of trouble-free service.*

# Model A Automatic Shrimp Peeler

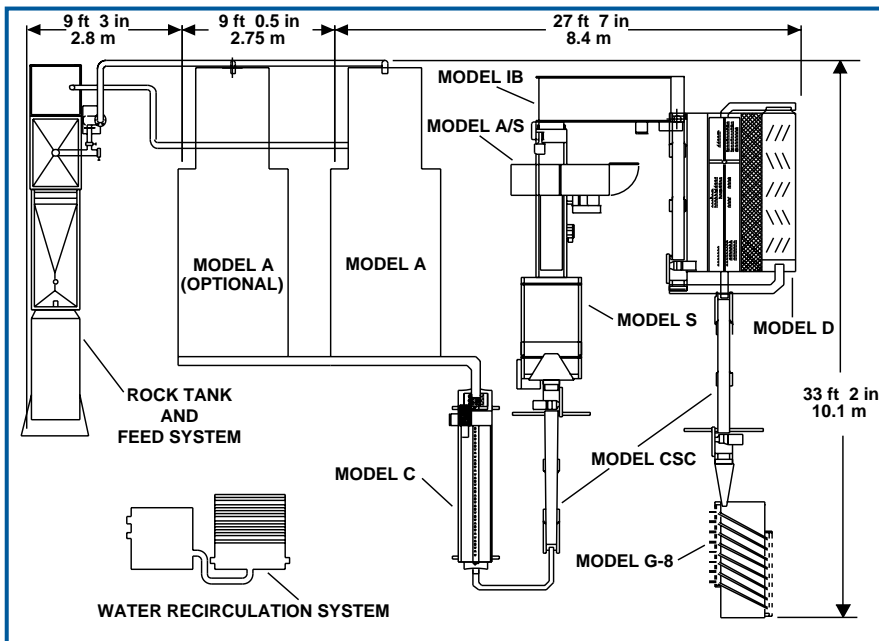
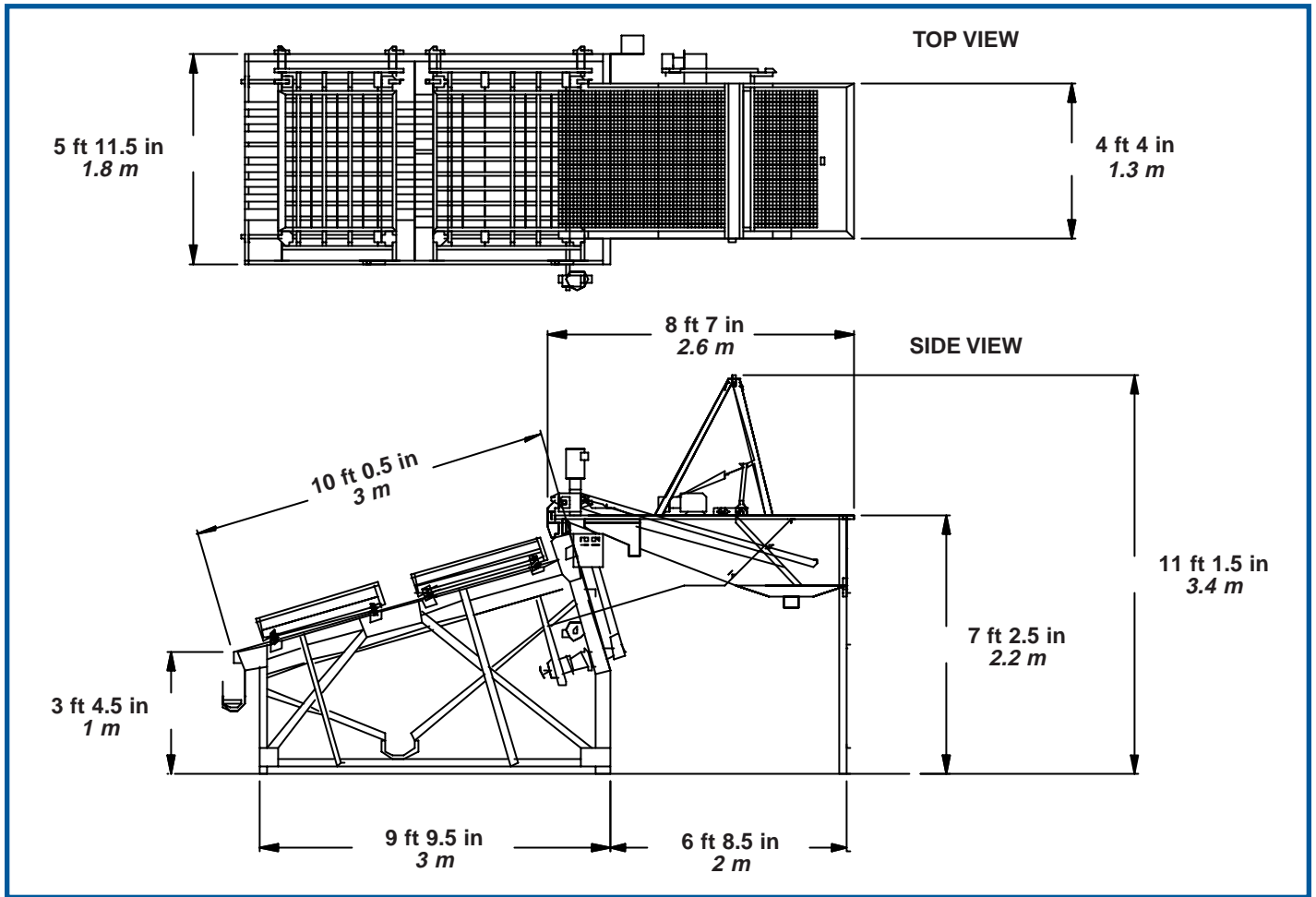

## TYPICAL PLANT LAYOUT

Suggested arrangement of a complete Laitram Model A shrimp processing line. Total floor space required with one peeler is approximately 900 ft<sup>2</sup> (84 m<sup>2</sup>). Each machine in the line can process the output of two Model A Automatic Shrimp Peelers (the second peeler is optional).

**Laitram  
Machinery**

Laitram Machinery, Inc. • P.O. Box 50699 • New Orleans, Louisiana 70150 • USA  
Tel: 504 733 6000 • Toll Free: 800 533 8253 • Fax: 504 733 6111  
Email: [lm.sales@laitram.com](mailto:lm.sales@laitram.com) • Internet: <http://www.laitram.com>