

Model RTFS Rock Tank & Feed System

**Laitram
Machinery**

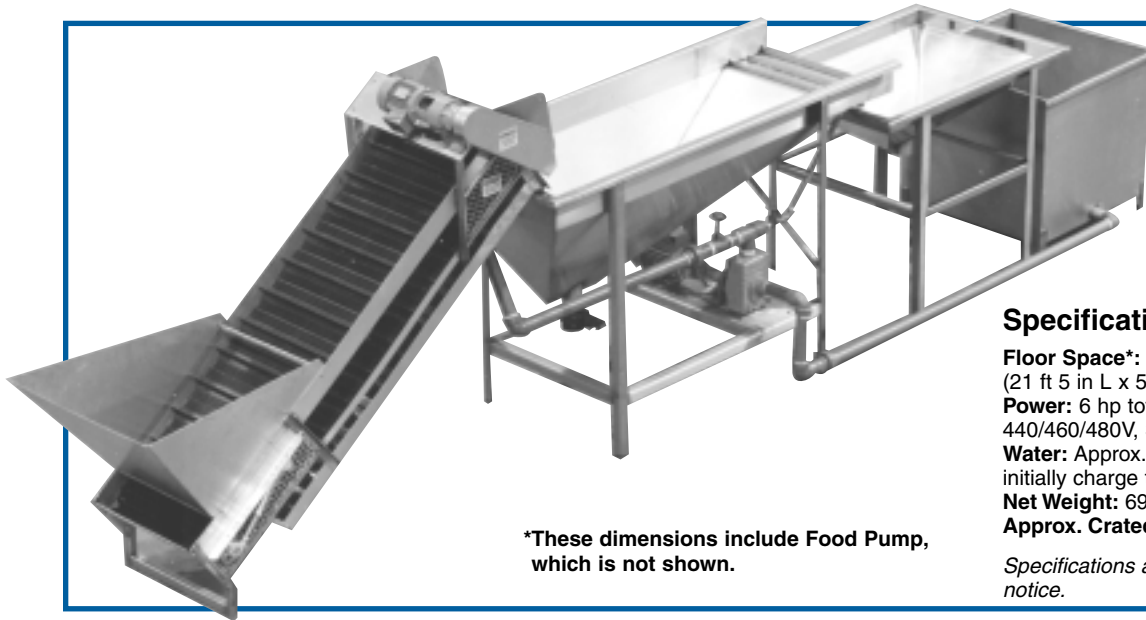

***These dimensions include Food Pump, which is not shown.**

Specifications:

Floor Space*: 6.55 m x 1.52 m x 1.93 m 10 m²
(21 ft 5 in L x 5 ft W x 6 ft 4 in H 107 ft²)

Power: 6 hp total, 220/230/240/380/
440/460/480V, 3 phase, 50/60 Hz

Water: Approx. 1515 liters (400 gallons) to initially charge the system.

Net Weight: 698 kg (1540 lb)

Approx. Crated Weight: 798 kg (1760 lb)

Specifications are subject to change without notice.

The Laitram® Model RTFS Rock Tank and Feed System can pre-clean enough shrimp to supply up to four peeling machines. The system removes foreign material (such as rocks, glass and shells) by use of turbulent water. Removal of damaging foreign objects reduces equipment maintenance and insures a higher quality end product. Cleaned shrimp are fed from the Model RTFS Rock Tank and Feed System to the peeler by way of a food pump specifically designed for delicate products. The system may be assembled in a straight line or in a right angle configuration. Constructed of stainless steel, all components will fully wash-down.

REDUCES WATER CONSUMPTION AND LABOR

The Model RTFS reduces water consumption by using water that overflows from the feed tank of any Laitram peeler. Loading the shrimp into the hopper of the feed conveyor is the only labor required.

LAITRAM QUALITY

Since 1949, Laitram has been a supplier of food processing equipment throughout the world. We have built our reputation on quality machinery, expert service and replacement parts. Call us. Together, we'll select the best system to meet your processing needs.



Loading shrimp into the Feed Conveyor Hopper is the only manual operation required until the Model IB Inspection Belt.



Cleaned shrimp are discharged from the Rock Tank into the Receiving Tank where the food pump gently sends shrimp to the Peeler.

Model RTFS Rock Tank & Feed System

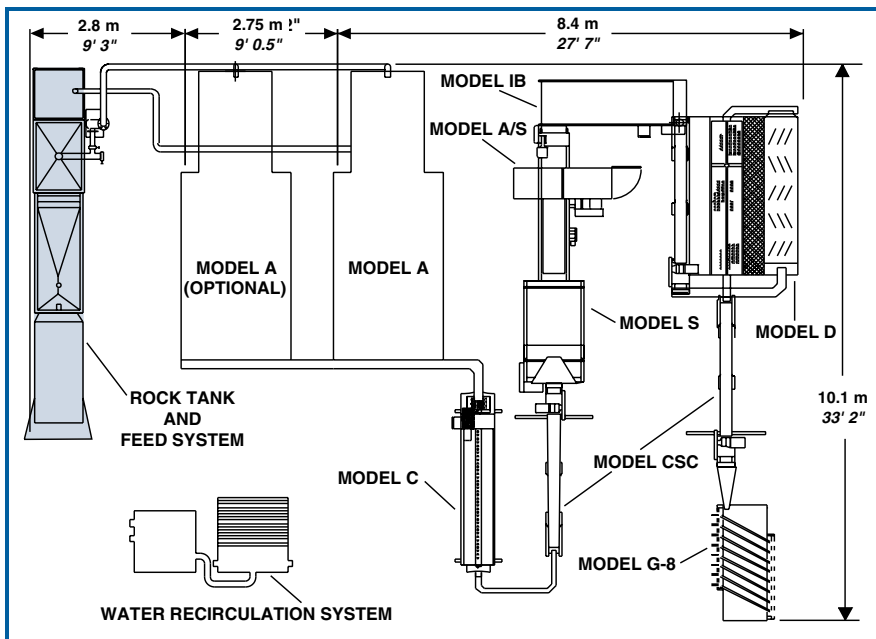
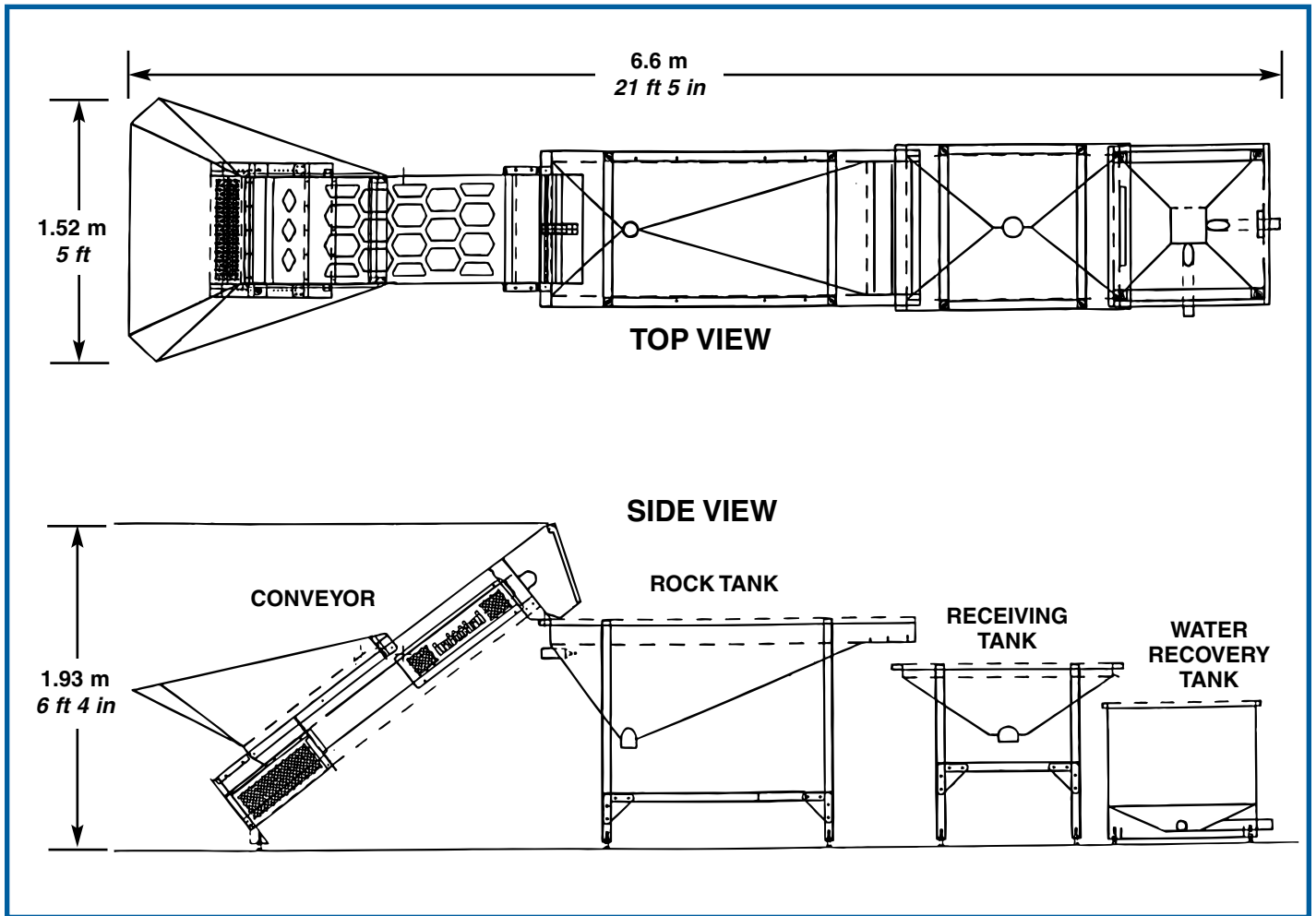

TYPICAL PLANT LAYOUT

Suggested arrangement of a complete Laitram® Warm Water Shrimp Processing System. Each machine in the line can process the output of the two Model A Peelers (the second peeler is optional). The Model RTFS will supply shrimp to a maximum of four peelers.

**Laitram
Machinery**

Laitram Machinery, Inc. • P.O. Box 50699 • New Orleans, Louisiana 70150 • USA
 Tel: (504) 733-6000 • Toll Free: (800) 533-8253 • Fax: (504) 733-6111
 Email: lm.sales@laitram.com • Internet: <http://www.laitrammachinery.com>