

Model IB Inspection Belt

**Laitram
Machinery**



Specifications:

Floor Space:

8 ft L (or 12 ft L) x 4 ft W x 3 ft H, 32 ft²
2.4 m (or 3.7 m) x 1.22 m x 0.9 m, 3 m²

Power: 1 hp total, 220/230/240/380/
440/460/480V, 3 phase, 50/60 Hz

Water: 5 gallons per minute (18.9 liters
per minute)

Net Weight: 500 lb (227 kg)

Approx. Crated Weight: 1,300 lb (590 kg)

The Laitram® Model IB Inspection Belt handles the output of two shrimp peeling machines. The Model IB is usually placed in the peeling line after the Model S Separator or Model AS Air Separator for manual inspection of peeled meat prior to deveining or grading. Offered in two lengths, 8 ft (2.4 m) and 12 ft (3.7 m), the Model IB can also be used as a stand-alone unit for other inspection applications.

EASILY CLEANED, RUGGED CONSTRUCTION

The Model IB Inspection Belt is easily cleaned. The motor is stainless steel and will fully wash-down. This stainless steel machine is equipped with non-corroding, modular plastic conveyor belting that will not contaminate, discolor or damage the product being inspected.

IN WORLDWIDE USE

Since 1949, Laitram has been a supplier of food processing equipment throughout the world. We have built our reputation on quality machinery, expert service and replacement parts. Call us. Together we'll select the best system to meet your processing needs.

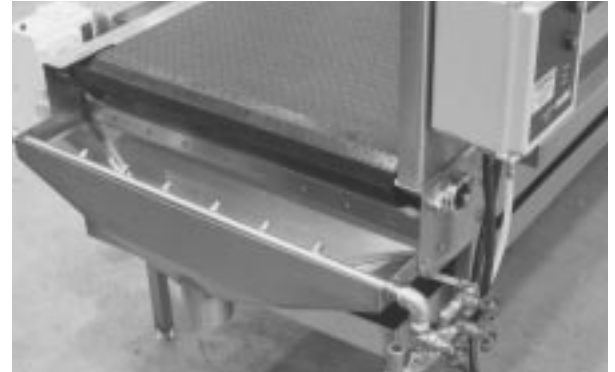

Spray bar at discharge of machine cleans shrimp off belt. Water conveys shrimp to the next machine in the line.

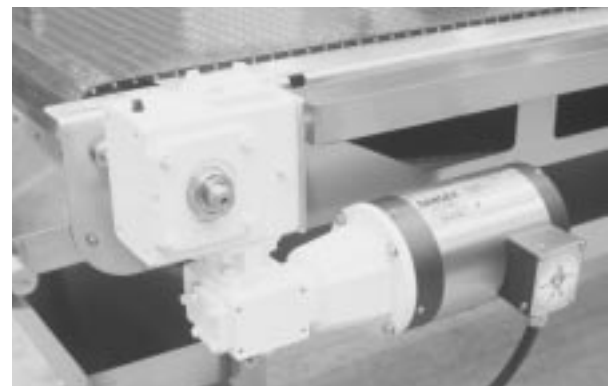

Shaft mounted gear reducer eliminates belts and chains, and is driven by an all stainless steel motor.

Model IB Inspection Belt

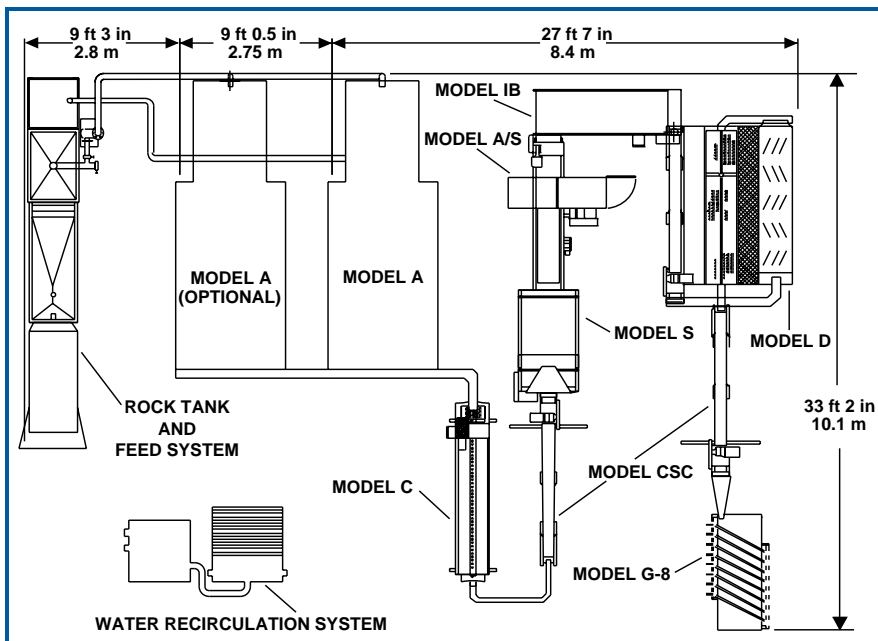
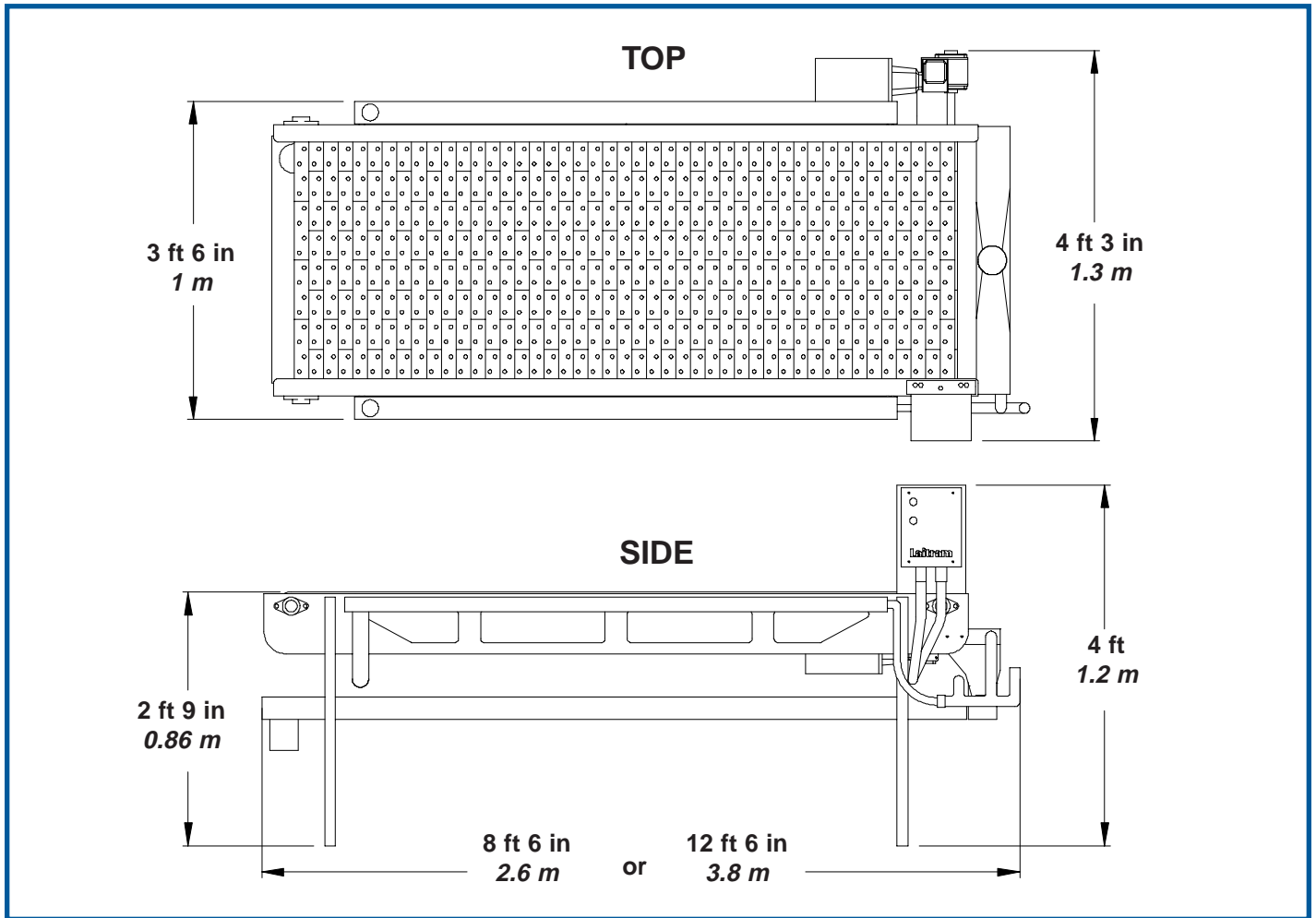

TYPICAL PLANT LAYOUT

Suggested arrangement of a complete Laitram Model A shrimp processing line. Total floor space required with one peeler is approximately 900 ft² (84 m²). Each machine in the line can process the output of two Model A Automatic Shrimp Peelers (the second peeler is optional).

**Laitram
Machinery**

Laitram Machinery, Inc. • P.O. Box 50699 • New Orleans, LA 70150 • USA
Tel: 504 733 6000 • Toll Free: 800 533 8253 • Fax: 504 733 6111
Email: lm.sales@laitram.com • Internet: <http://www.laitram.com>