

Model CSC Lift Conveyor

**Laitram
Machinery**



Specifications

Floor Space:

3.4 m x 1 m; 3.4 m²
(11 ft 1 in x 3 ft 2 in; 35 ft²)

Power: Available in most major voltages, including 208/220/240/480V (60 cycle), and 380 V (50 cycle); 3 phase. 1 hp motor included.

Water: 11-19 LPM per minute (3-5 GPM).

Belt Speed: 30 mpm (100 ft per minute).

Net Weight: 80 kg (177 lb)

Approx. Gross Crated Weight: 224 kg (495 lb)

Specifications are subject to change without notice.

The Model CSC Lift Conveyor elevates raw or cooked, peeled shrimp from the Model C or Model PCC Cleaner to the Model S or Model PCS Roller Separator. It also conveys product from the Model IB Inspection Belt or Model D Deveiner to the Model G-8 Grader.

HIGH CAPACITY

The Model CSC conveys the output of up to two Laitram peelers (whether warm or cold water). It can also be used to convey other products within the plant. The belt is 20 cm (8 inches) in width and moves at a rate of approximately 30 mpm (100 feet per minute). Belts are available with or without flights.

EASY TO OPERATE AND CLEAN

Like all Laitram equipment, the Model CSC is constructed of type 304 stainless steel and is easy to clean. Once initial adjustments are made, it requires little or no supervision. All components are precision machined and assembled.

LAITRAM QUALITY

Since 1949, Laitram has been a supplier of food processing equipment throughout the world. We have built our reputation on quality machinery and exceptional service. Call us. Together, we'll select the best system to meet your processing needs.



Water spray line at top of conveyor insures the complete discharge of shrimp.

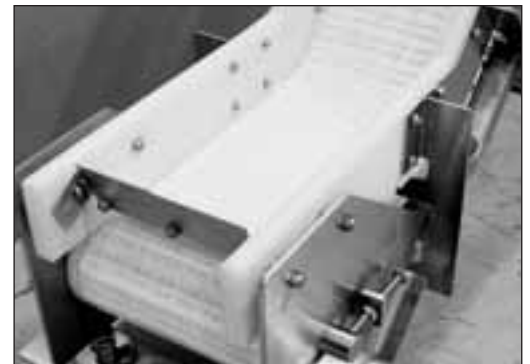

Non-corroding, all-plastic conveyor belt is used for easy cleaning.

Model CSC Lift Conveyor

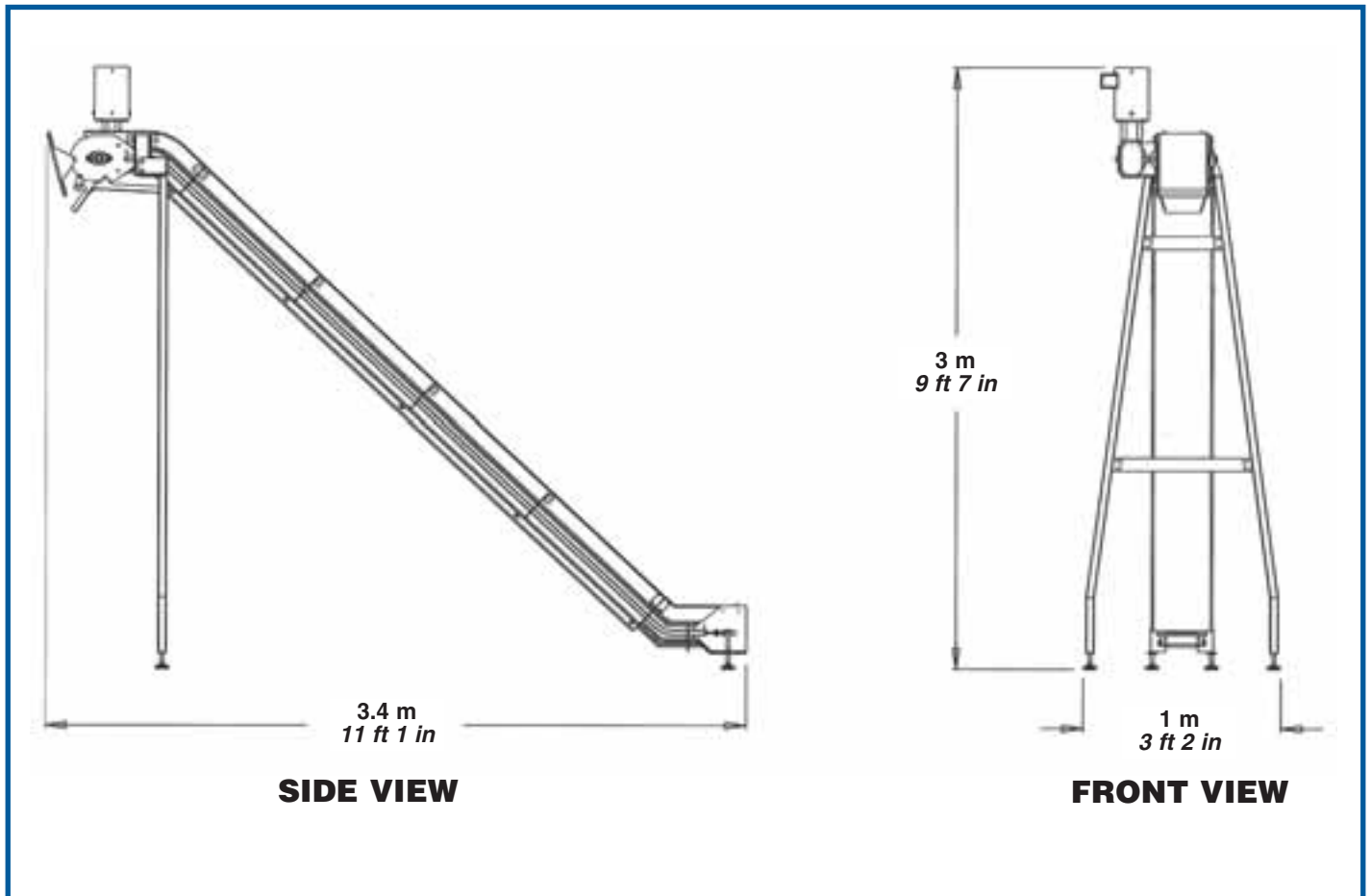

The Model CSC is available in other lengths and heights depending upon plant requirements.

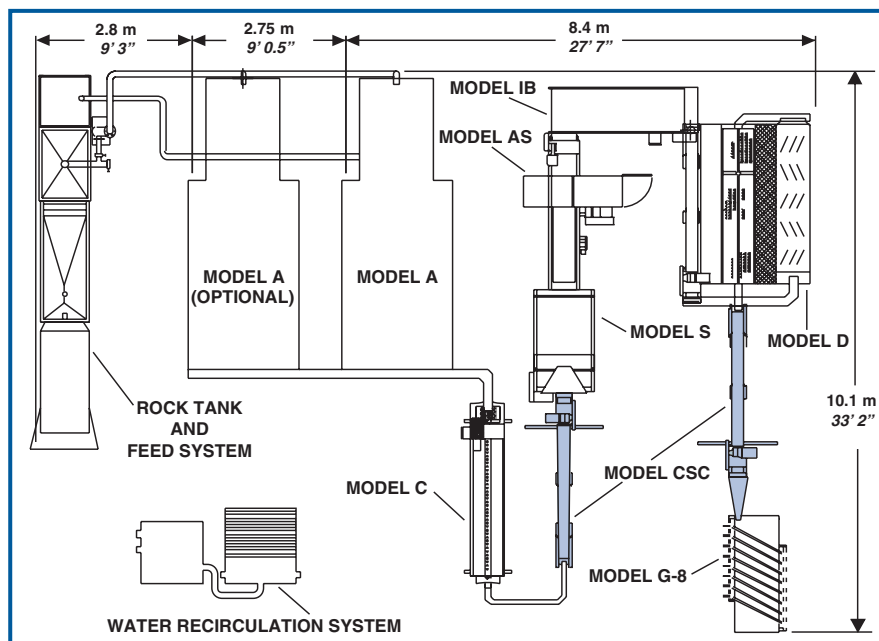

TYPICAL PLANT LAYOUT

Suggested arrangement of a complete Warm Water Shrimp Processing System. Each machine in the line can process the output of two Model A Automatic Shrimp Peelers (the second peeler is optional).



Laitram Machinery, Inc. • P.O. Box 50699 • New Orleans, Louisiana 70150 • USA
 Tel: 504 733 6000 • Toll Free: 800 533 8253 • Fax: 504 733 6111
 Email: lm.sales@laitram.com • Internet: www.laitrammachinery.com