

Model C Shrimp Cleaner

**Laitram
Machinery**



Oscillating screen, located on in-feed end, provides a water flow adjustment to insure that the proper amount of waste is detached.



A series of spring loaded wheels oscillate within a rubber coated or stainless steel flume to detach swimmerets, gristle and other waste.

The Model C Shrimp Cleaner completes the peeling process by detaching remaining swimmerets, gristle and other waste from edible meats. Shrimp are flumed through a rubber coated or optional stainless steel vessel where a series of spring loaded, oscillating wheels gently detach waste material from the shrimp. This process plays an important role in obtaining a quality, finished product and high yield. The Model C is used in line directly after the Model A Peelers.

EASY TO OPERATE AND CLEAN

Like all Laitram equipment, the Model C is constructed of stainless steel and is easy to clean. Once initial adjustments are made, it requires little or no supervision. All components are precision machined and assembled.

LAITRAM QUALITY

Since 1949, Laitram has been a supplier of food processing equipment throughout the world. We have built our reputation on quality machinery, service and replacement parts. Call us. Together, we'll select the best system to meet your processing needs.

Model C Shrimp Cleaner

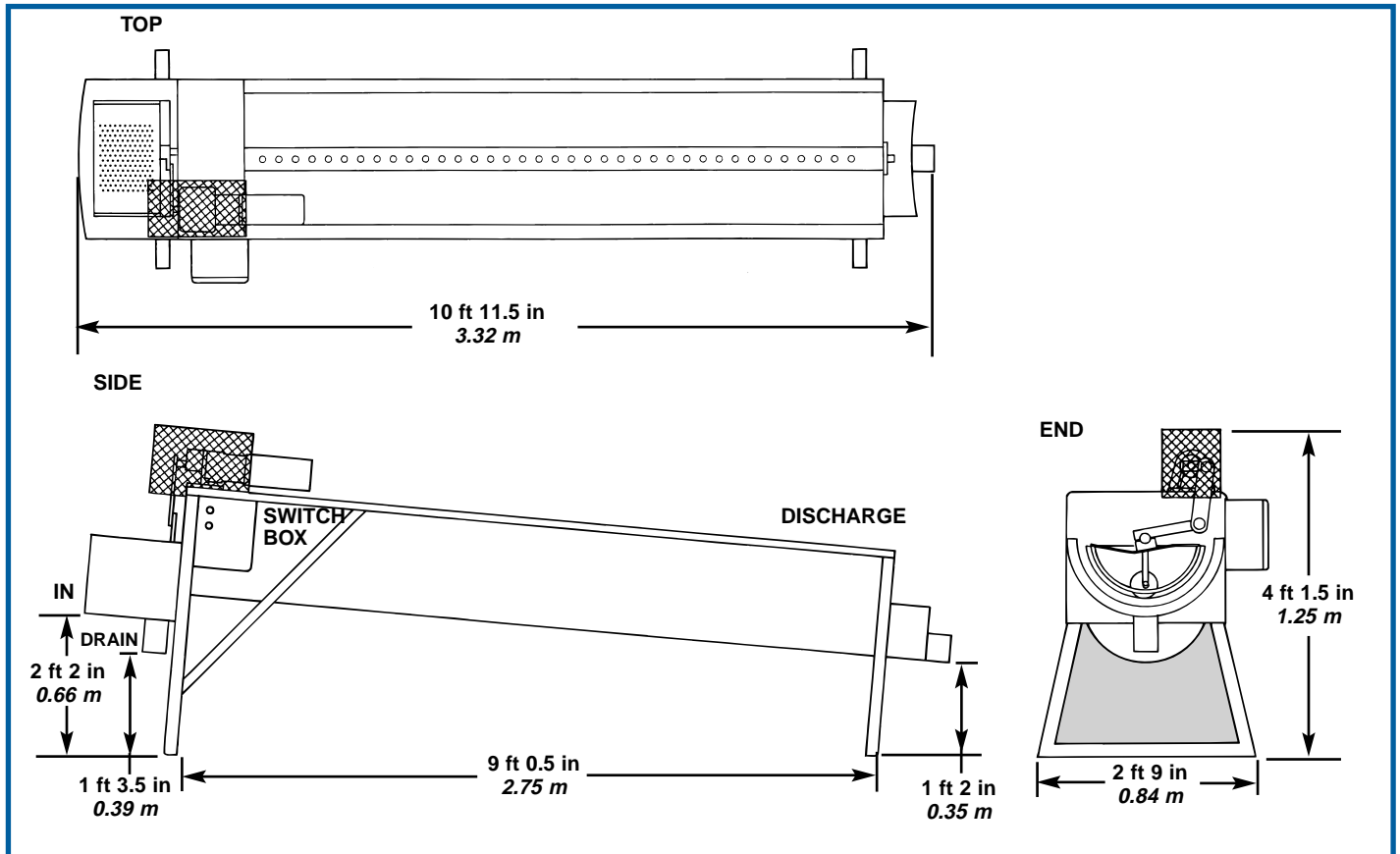

Specifications

Floor Space:

2 ft 9 in x 10 ft 11 1/2 in; 30 ft²
(0.84 m x 3.32 m; 2.8 m²)

Power: Available in most major voltages, including 208/220/240/480 V (60 cycle), and 380 V (50 cycle); 3 phase. 1 hp motor included.

Water: Water discharge from peeler is sufficient.

Net Weight: 650 lb (295 kg)

Approx. Gross Crated Weight:
750 lb (340 kg)

Specifications are subject to change without notice.

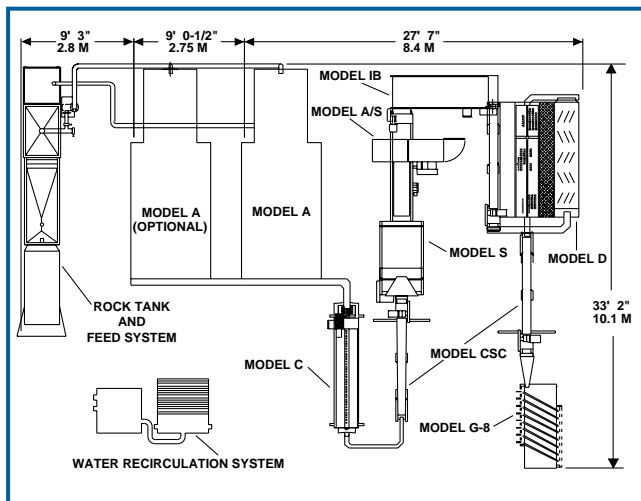

TYPICAL PLANT LAYOUT

Suggested arrangement of a complete Laitram Model A shrimp processing line. Total floor space required with one peeler is approximately 900 ft² (84 m²). Each machine in the line can process the output of two Model A Automatic Shrimp Peelers (the second peeler is optional).

**Laitram
Machinery**

Laitram Machinery, Inc. • P.O. Box 50699 • New Orleans, Louisiana 70150 • USA
Tel: 504 733 6000 • Toll Free: 800 533 8253 • Fax: 504 733 6111
Email: lm.sales@laitram.com • Internet: www.laitrammachinery.com