

Model AS-MAX Air Separator

**Laitram
Machinery**



Specifications

Floor Space:

4.2 m x 1.6 m; 6.72 m²
(13 ft 11.1 in x 5 ft 2 in; 70 ft²)

Power: Available in most major voltages, including 208/220/240/480 V (60 cycles), and 380 V (50 cycles); 3 phase. 10 hp blower motor and 1 hp gear motor included.

Approx. Gross Shipping Weight:
1075 kg (2370 lb)

Specifications are subject to change without notice.

The Laitram[®] Model AS-MAX Air Separator completes the automated cleaning process. It conveys raw or cooked, peeled shrimp through an air chamber where waste material is separated from edible meats. It also aids in removing water from shrimp prior to final visual inspection.

HIGH CAPACITY

Powered by a 10 hp blow motor, the AS-MAX can easily process 1100 kg/hr (2400lb/hr) of peeled meat and 3270 kg/hr (7200 lb/hr) of raw infeed product, equaling the output of up to 4 warm or cold water peelers.

EASY TO CLEAN AND OPERATE

In addition to high capacity, the AS-MAX was designed for easy access cleaning. The poly sides are removable and the motor and fan swing out for more effective cleaning. Like all Laitram equipment, the AS-MAX is constructed of stainless steel.

LAITRAM QUALITY

Since 1949, Laitram Machinery, Inc. has been a supplier of food processing equipment throughout the world. We have built our reputation on quality machinery, expert service and spare parts. Call us. Together, we'll select the best system to meet your processing needs.



Pulsating fan allows you to feed all sizes of shrimp through blower at the same time, without adjusting motor speed.



Poly sides are removable for easy cleaning.

Model AS-MAX Air Separator

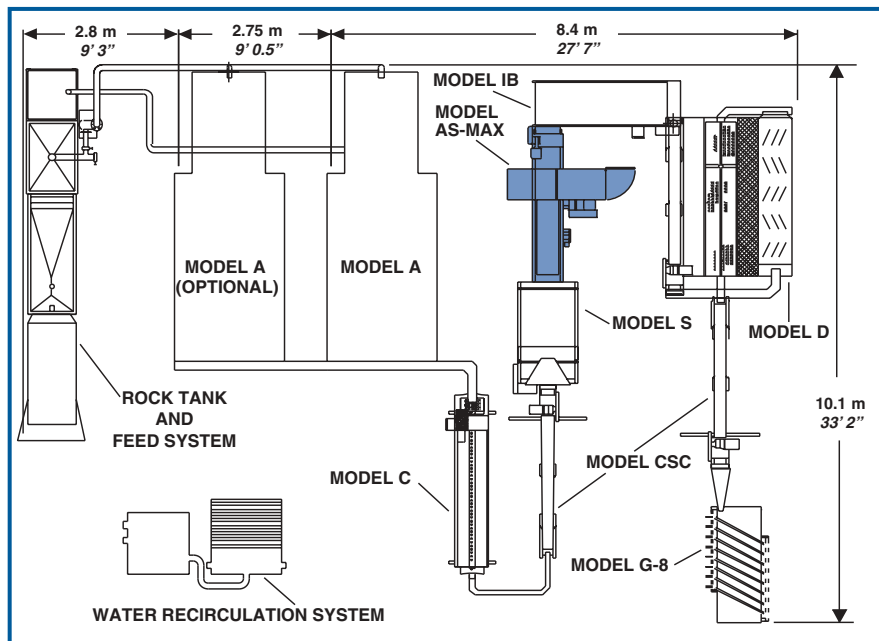
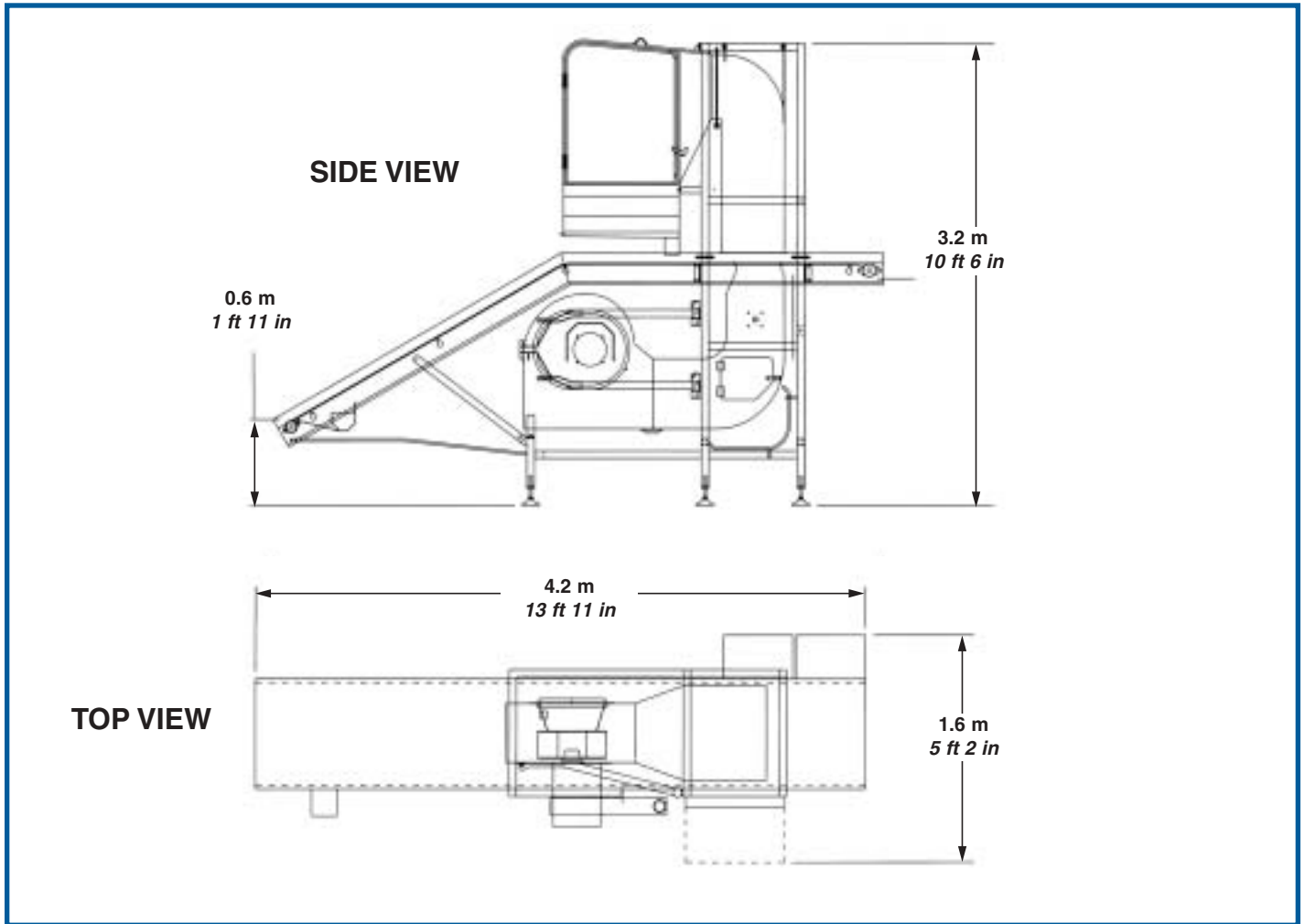

TYPICAL PLANT LAYOUT

Suggested arrangement of a complete Laitram Warm Water Shrimp Processing System. Each machine in the line can process the output of two Model A automatic shrimp peelers (the second peeler is optional).

The AS-MAX can process the output of up to four Laitram warm water or cold water peelers.

**Laitram
Machinery**

Laitram Machinery, Inc. • P.O. Box 50699 • New Orleans, Louisiana 70150 • USA
Tel: 504 733 6000 • Toll Free: 800 533 8253 • Fax: 504 733 6111
Email: lm.sales@laitram.com • Internet: www.laitrammachinery.com