

Model AS Air Separator

**Laitram
Machinery**

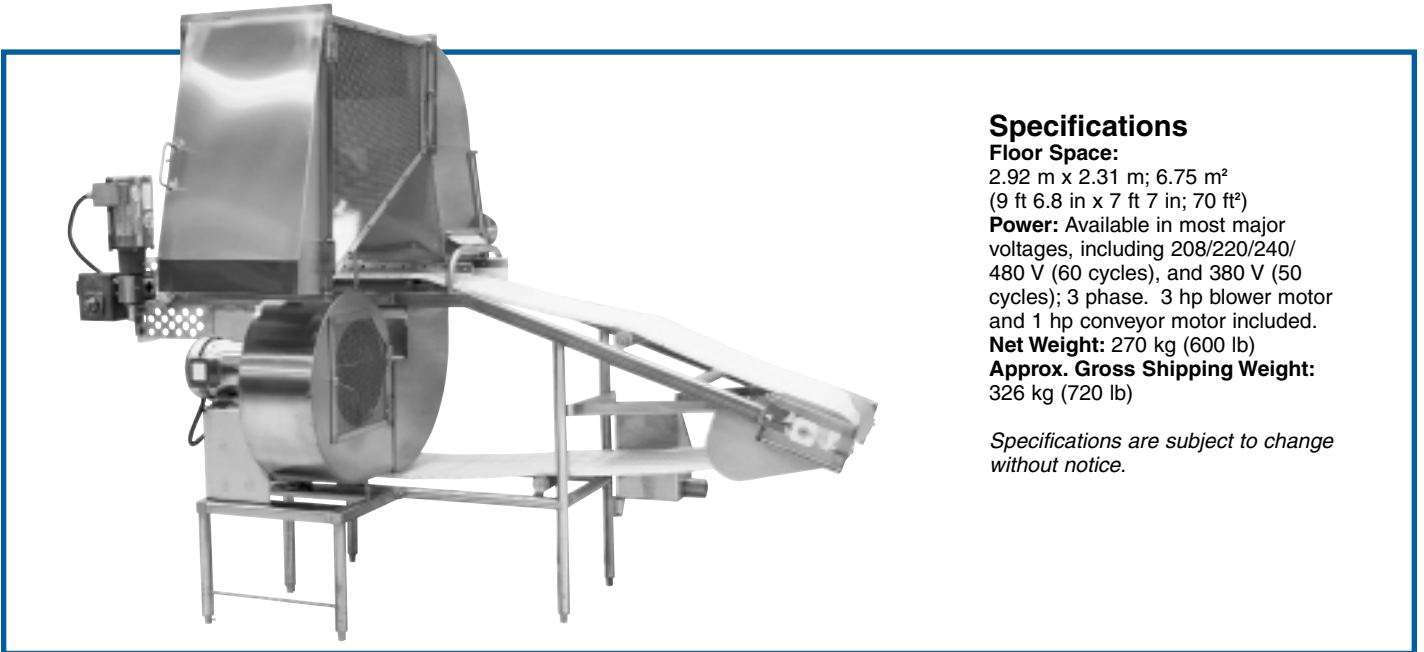

Specifications

Floor Space:

2.92 m x 2.31 m; 6.75 m²
(9 ft 6.8 in x 7 ft 7 in; 70 ft²)

Power: Available in most major voltages, including 208/220/240/480 V (60 cycles), and 380 V (50 cycles); 3 phase. 3 hp blower motor and 1 hp conveyor motor included.

Net Weight: 270 kg (600 lb)

Approx. Gross Shipping Weight: 326 kg (720 lb)

Specifications are subject to change without notice.

The Laitram® Model AS Air Separator completes the automated cleaning process. It conveys raw or cooked, peeled shrimp through an air chamber where waste material is separated from edible meats. It also aids in removing water from shrimp prior to final visual inspection.

FLEXIBLE AND PRECISE

Air flow in the Model AS is precisely controlled in 1 Hz increments by an AC speed inverter. A wide range of air flow settings accommodates almost any size shrimp.

EASY TO OPERATE AND CLEAN

Like all Laitram equipment, the Model AS is constructed of stainless steel. It is outfitted with an all-plastic, modular conveyor belt for easy cleaning. Once initial adjustments are made, the Model AS requires little or no supervision. All components are precision machined and assembled.

LAITRAM QUALITY

Since 1949, Laitram Machinery, Inc. has been a supplier of food processing equipment throughout the world. We have built our reputation on quality machinery, expert service and spare parts. Call us. Together, we'll select the best system to meet your processing needs.



Variable speed blower provides a wide range of controlled air flows.

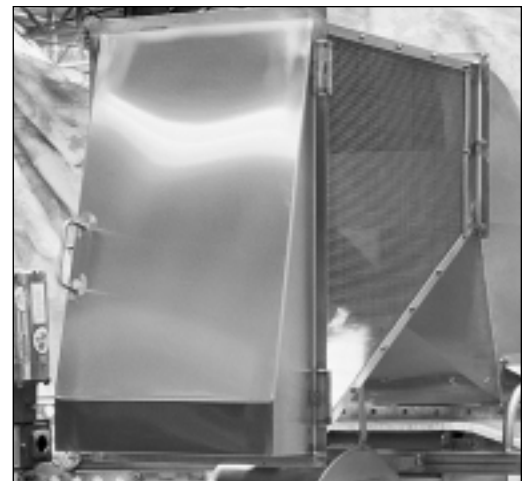

Screen hood can be mounted to face right or left for optimum space utilization.

Model AS Air Separator

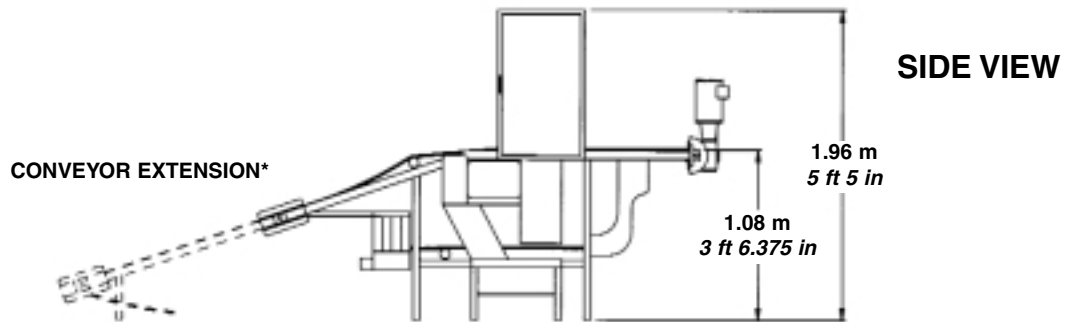
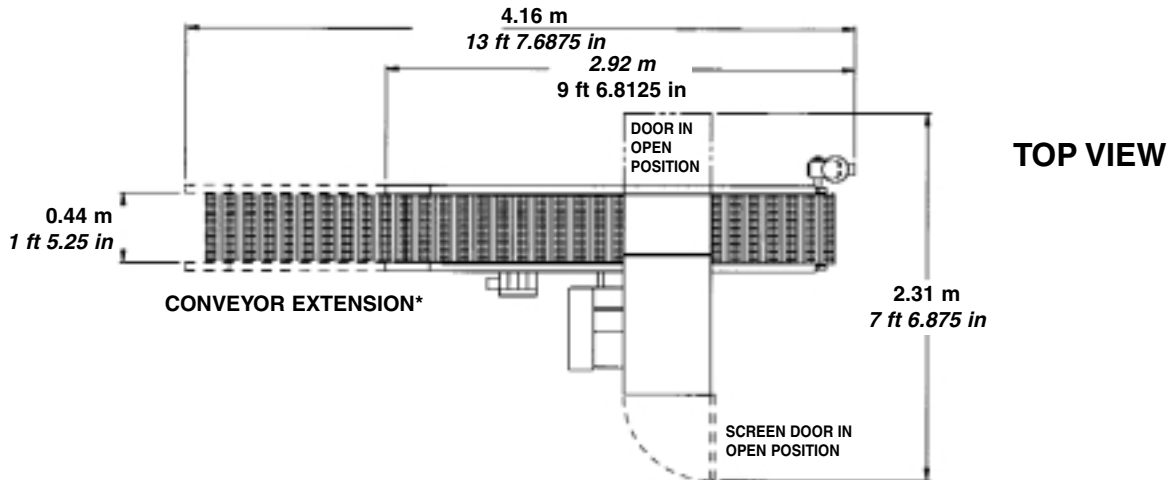

*Model AS is also available with extended conveyor as indicated with dash lines.

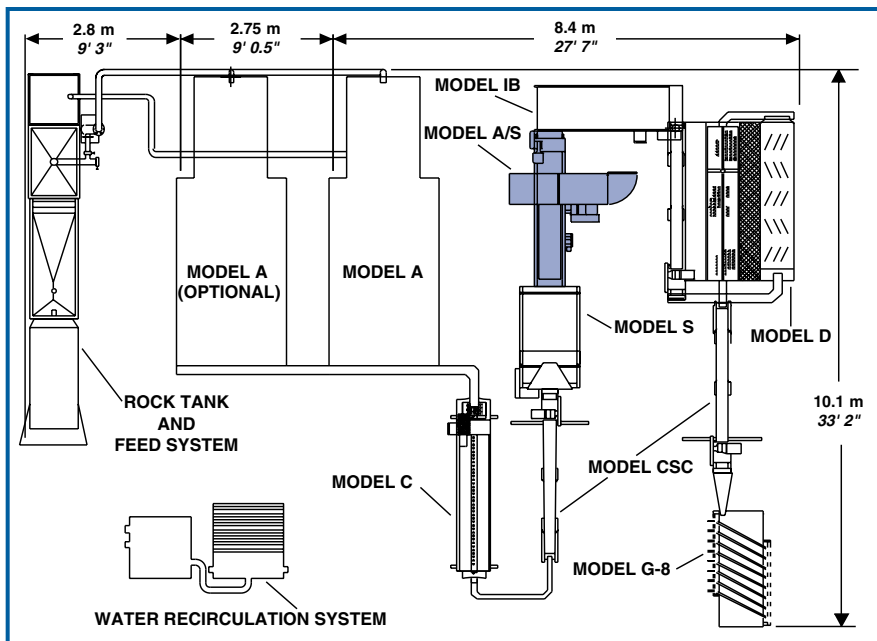

TYPICAL PLANT LAYOUT

Suggested arrangement of a complete Laitram Warm Water Shrimp Processing System. Each machine in the line can process the output of two Model A automatic shrimp peelers (the second peeler is optional).



Laitram Machinery, Inc. • P.O. Box 50699 • New Orleans, Louisiana 70150 • USA
 Tel: 504 733 6000 • Toll Free: 800 533 8253 • Fax: 504 733 6111
 Email: lm.sales@laitram.com • Internet: <http://www.laitrammachinery.com>