

Model AG 70 Adjustable Grading System

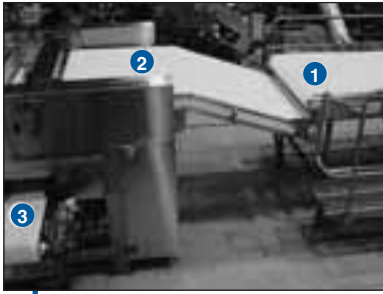

Grading is extremely gentle with only three transfer points.
 1) Wash Tank/Inspection Belt to Intermediate Conveyor
 2) Intermediate Conveyor to Grader
 3) Grader to Take Out Conveyor
 This produces a higher quality product and minimizes yield loss.



The grader's continuously rotating rollers accurately and gently size shrimp.

Laitram's Model AG 70 Adjustable Grading System provides highly accurate grading, gentle product handling, high capacity, and easy operation and maintenance. The complete grading system includes a feed and wash tank, an inspection belt, the Model AG 70 Adjustable Grader, and two take-out conveyors. Take-out and packing conveyors can be customized to meet processors' specific needs.

Gentle Handling

The Model AG 70 Adjustable Grading System is ideal for grading delicate products such as head-on shrimp and headless shrimp. Progressively increasing gaps between slowly rotating rollers gently sort the shrimp. With only three transfer points in the entire grading system, product damage is minimized.

High Accuracy and Compact Design

To facilitate high accuracy, variable speed controls regulate throughput as desired. Two rail adjustment handles control roller spacing and allow quick adjustment of grades anytime. Additionally, the system's compact dimensions save valuable plant space.

Laitram Quality

Since 1949, Laitram has been a supplier of food processing equipment throughout the world. We have built our reputation on quality equipment and exceptional service. Call us. Together, we'll select the best system to meet your processing needs.

Performance Summary	
Capacity	Up to 1800 kg (up to 4000 lb) ¹ per hour
Grading Range	6 - 7 grades of head-on or headless shrimp
Uniformity Ratio	Consistently 1.5 or better — as accurate as 1.3 or better, depending on capacity. ²
All results depend on type and quality of raw material.	

¹ Depending on size and uniformity desired.

² Without pre- or post-inspection of product.

Model AG 70 Adjustable Grading System

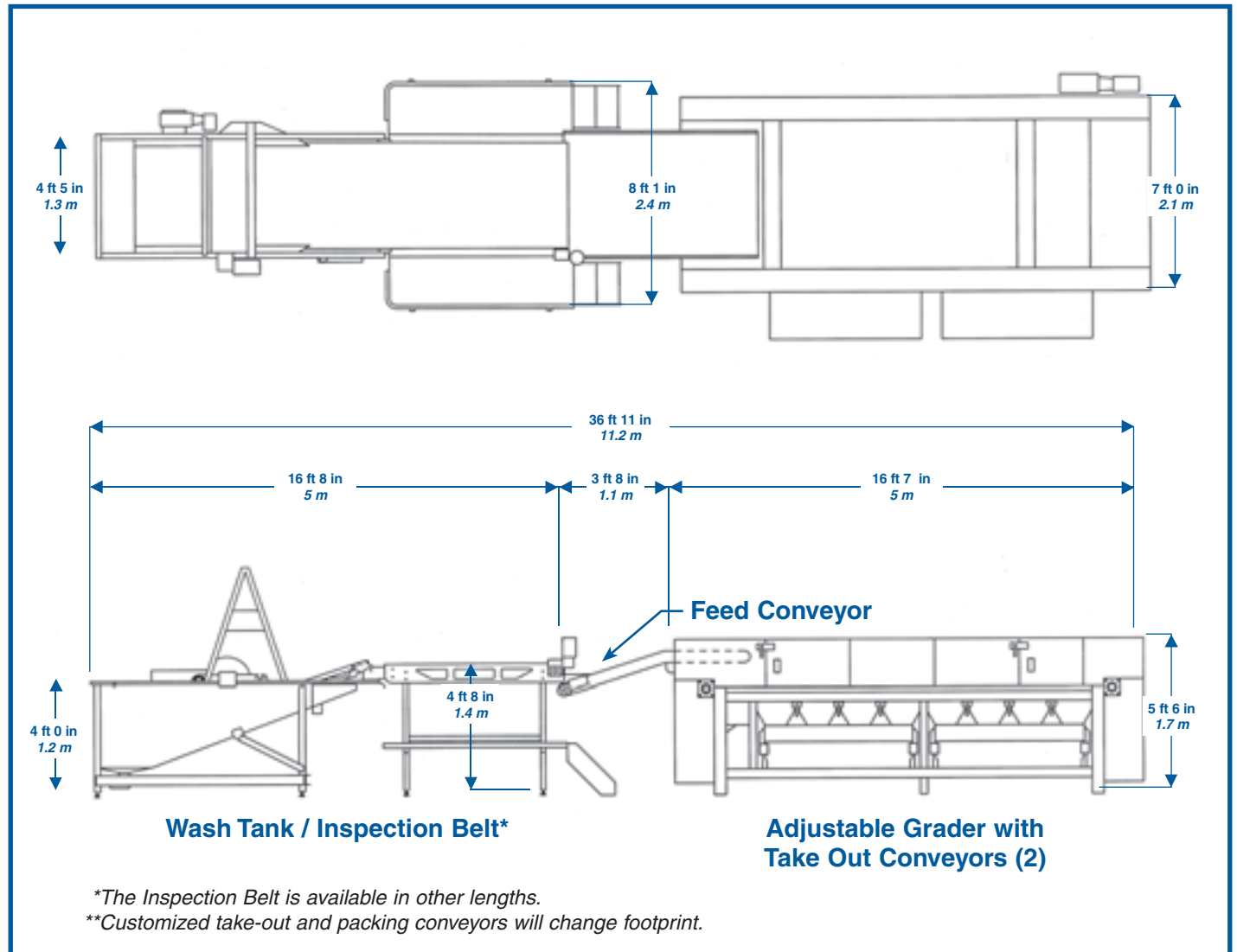

Specifications

Approx. Capacity Per Hour:

4000 - 5000 lb (1814 - 2268 kg)*

Product Size Range:

Grades from 10 - 90 count per lb (22 - 198 count per kg)

Uniformity Ratio:

Consistently 1.5 or better — as accurate as 1.3 or better depending on capacity**

Water:

Wash Tank: 5 GPM (19 LPM)

Wash Tank/Inspection Belt: 19 LPM (5 GPM)

Grader: 75-83 LPM (20-22 GPM)

Power:

Available in most major voltages, including 208, 220, 240, 480V (60 cycle), and 380V (50 cycle); 3 phase.

Wash Tank: (1) 1 HP motor

Wash Tank/Inspection Belt: (3) 1 HP motor

Grader: (1) 3 HP motor

Take Out Conveyors: (2) 1 HP motors

Net Weight:

Grader with Take Out Conveyors:

5915 lb (2683 kg)

Specifications are subject to change without notice.

**Depending on size range of raw material.*

***Without pre- or post-inspection of product.*

**Laitram
Machinery**

Laitram Machinery, Inc. • P.O. Box 50699 • New Orleans, Louisiana 70150 • USA

Tel: 504 733 6000 • Toll Free: 800 533 8253 • Fax: 504 733 6111

Email: lm.sales@laitram.com • Internet: www.laitrammachinery.com