

FC200 Bulk/Tray Cooker

**Laitram
Machinery**

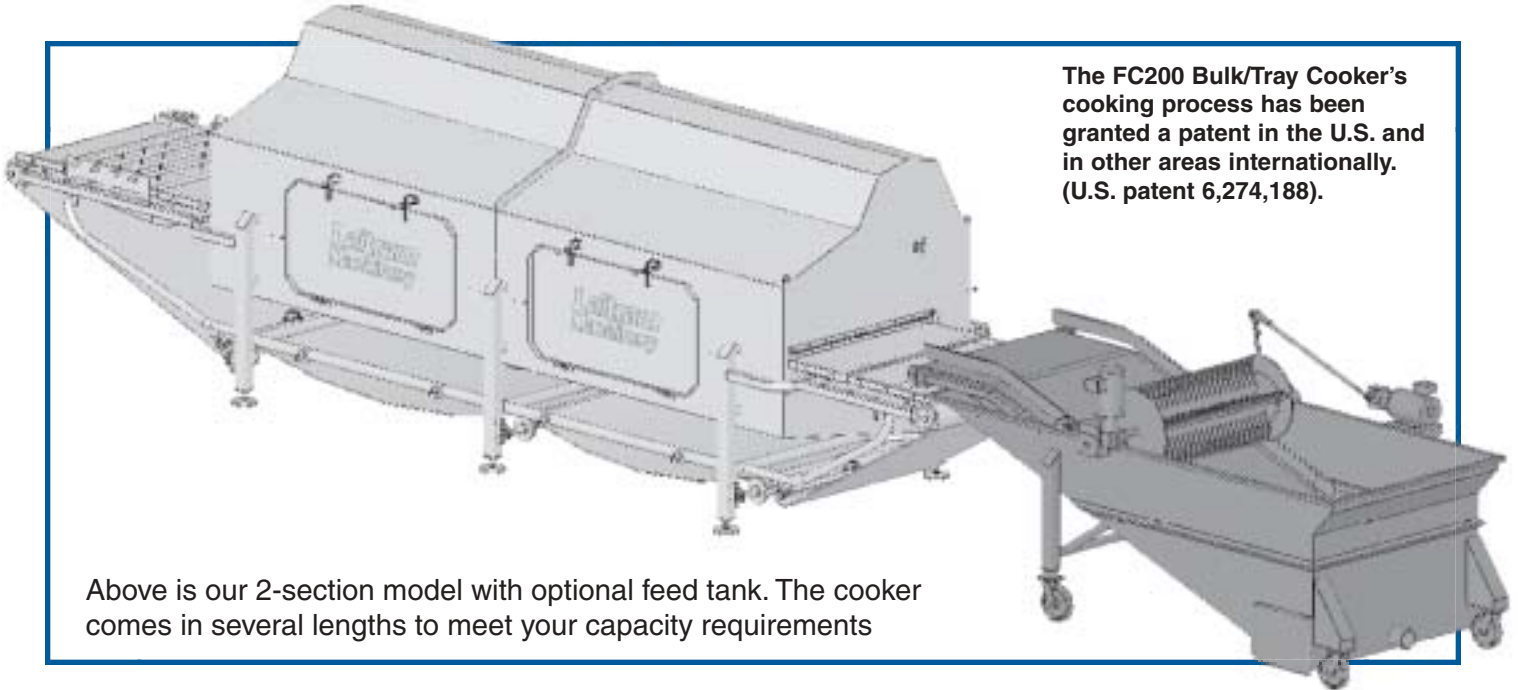

The FC200 Bulk/Tray Cooker's cooking process has been granted a patent in the U.S. and in other areas internationally. (U.S. patent 6,274,188).

Above is our 2-section model with optional feed tank. The cooker comes in several lengths to meet your capacity requirements

The Laitram Model FC200 Bulk/Tray Cooker features a patented, "forced convection" process allowing the flexibility to cook shrimp using tray or bulk-feeding for peeled tail-on, fully peeled, or shell-on shrimp. Simply roll the feed tank into position when bulk-feeding, and roll it away when cooking with trays.

PATENTED PROCESS ACHIEVES HIGHER YIELD

The FC200 Bulk/Tray Cooker creates a homogenized mixture of steam and air. A more uniform cooking temperature and heat transfer is maintained as the product is gently conveyed through the forced convection process, resulting in a higher yield of better looking and tasting shrimp.

EASY TO CLEAN AND MAINTAIN

The 316L grade stainless steel construction of the FC200 is specially treated for maximum corrosion resistance. Large doors are carefully positioned on both sides for easy access, while an Intralox™ belt provides the best durability and sanitation inside the cooker.

ENERGY EFFICIENT

The forced convection method allows a pre-set cooking temperature of 85-90°C, reduced from the conventional 100°C. More shrimp is cooked with less steam and heat loss, resulting in energy savings.

LAITRAM QUALITY

Since 1949, Laitram has been a supplier of food processing equipment throughout the world. We have built our reputation on quality machinery, expert service and replacement parts. Call us. Together, we'll select the best system to meet your processing needs.

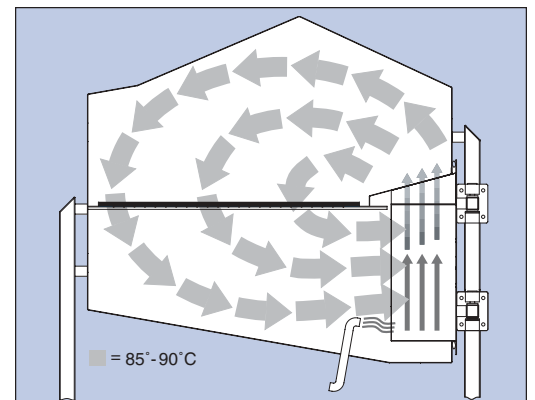

Forced Convection: a mixture of steam and air, creates a more uniform cooking temperature.



Large doors are located on both sides of FC200, allowing easy access for cleaning and maintenance.

FC200 Bulk/Tray Cooker

	CAPACITY* kg/hr (lbs/hr)									STEAM	WATER
	TRAY-COOKING			BULK-COOKING							
				FULLY PEELED			SHELL-ON				
	21-25**	41-50**	90-110**	21-25**	41-50**	90-110**	21-25**	41-50**	90-110**		
FC200 2-section	400 (850)	500 (1100)	600 (1320)	450 (950)	550 (1200)	650 (1400)	500 (1100)	600 (1300)	700 (1500)	100 kg/hr (220 lb/hr)	1.6 m ³ /hr (56.5 ft ³ /hr)
FC200 3-section	600 (1300)	750 (1650)	900 (1950)	675 (1450)	825 (1800)	975 (2150)	750 (1650)	900 (1950)	1050 (2300)	150 kg/hr (330 lb/hr)	2 m ³ /hr (70.6 ft ³ /hr)
FC200 4-section	800 (1750)	1000 (2200)	1200 (2600)	900 (1950)	1100 (2400)	1300 (2850)	1000 (2200)	1200 (2600)	1400 (3050)	200 kg/hr (440 lb/hr)	2 m ³ /hr (70.6 ft ³ /hr)

* All capacities are approximate.

** Shrimp counts.

Specifications subject to change without notice.

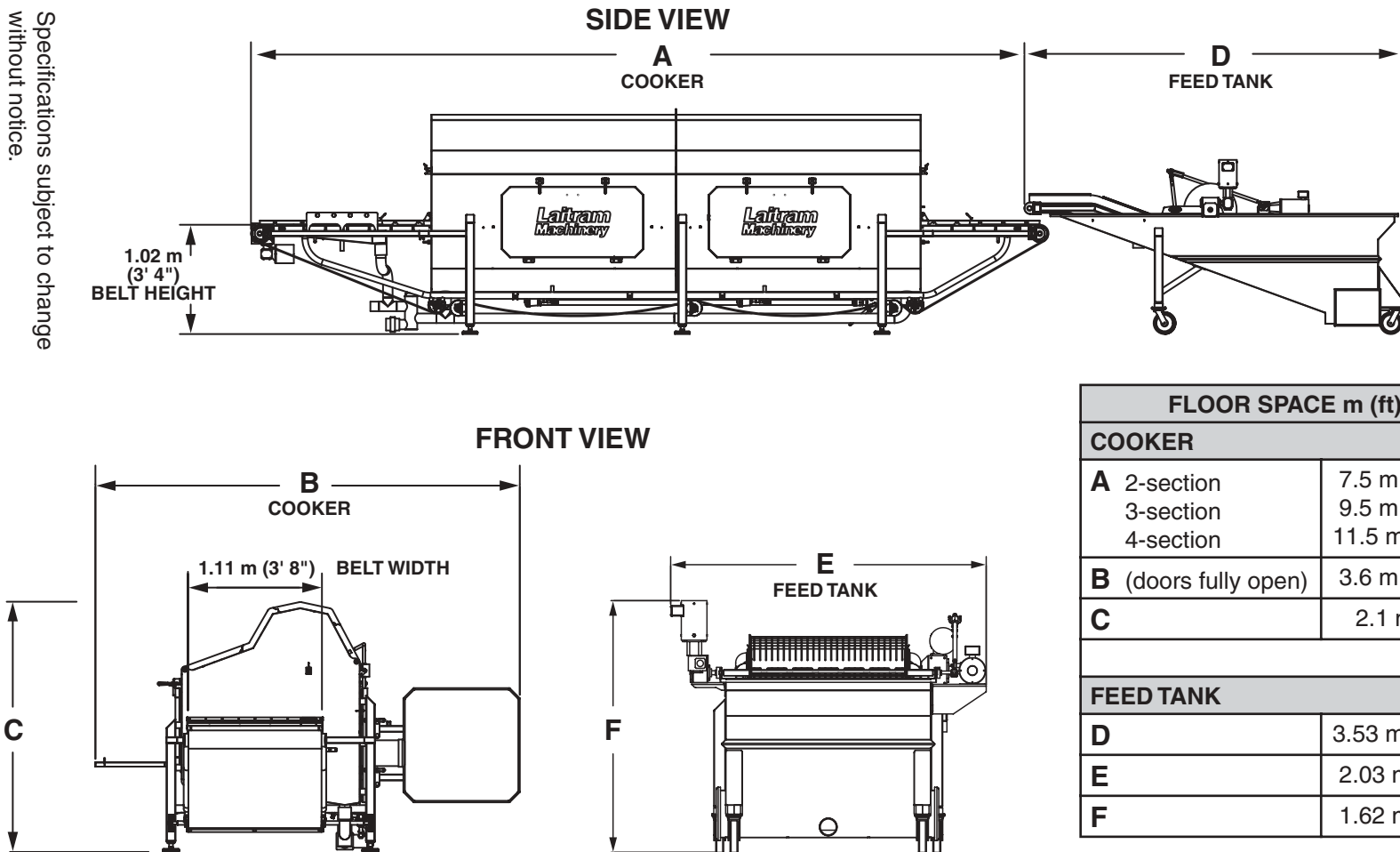

FLOOR SPACE m (ft)	
COOKER	
A 2-section	7.5 m (24.6')
3-section	9.5 m (31.1')
4-section	11.5 m (37.7')
B (doors fully open)	3.6 m (11.8')
C	2.1 m (7')
FEED TANK	
D	3.53 m (11.7')
E	2.03 m (6.8')
F	1.62 m (5.4')